



FLOAT TYPE AUTODRAIN



SPECIFICATION

Dimensions	High - 18cm (7")	Diameter - 10cm (4")
Weight	0.78 kg	
Inlet Port	1/2" PT	
Outlet Port	3/8" PT	
Operating Pressure	1.3-13 kg/cm ² (20-185 PSI)	
Operating Temp	2-60°C (36-140°F)	
Function	60 cc/per one time Max. operation 25 times per minute	

FEATURES

- With large diameter sized entrance and path to permit particles and rust, no accumulation will occur in dead corners.
- Aluminium alloy casting with special anti-corrosion treatment and then coated with high quality baking varnish can withstand acid and base without any corrosion occurring.
- Large volume filtered dirt toring compartment can filter and store more rust and dirt than other common automatic drain valve.
- Water collecting bowl, made of optical class transparent plastic material, will not rupture.
- Implanted stainless rod for float will never slip off.
- Large size float has more buoyancy and is more sensitive to control.
- Large size water collecting bowl can store and drain more water thus reduce the draining time and increase the service life of automatic drain valve.
- Leakage proof ring, made of high quality VITON rubber, can endure abrasion without leakage. Its service time is ten times longer than NBR rubber.

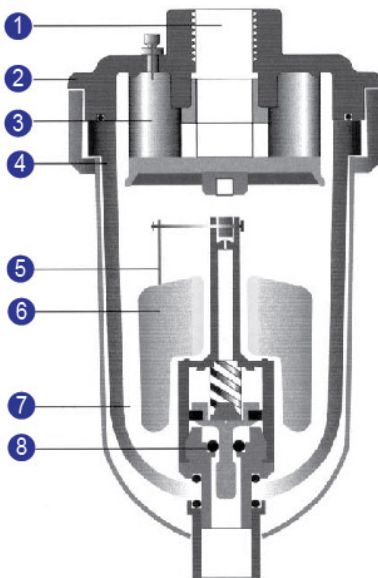

Authorised Distributor :



NEPTEC ENGINEERING SDN BHD

No. 33-1, Jln Kebun Nenas 4A/KS 8, (1068405-P)
 Bandar Putera 2, 41200 Klang, Selangor.
 Website : www.neptec.com.my
 Tel : 03-5161 3330
 Fax : 03-5161 3331

H/P : 012-223 8681
 Email : sales@neptec.net

H/P : 012-664 2440
 Email : tcgan@neptec.net

H/P : 012-289 9720
 Email : ts@neptec.net